

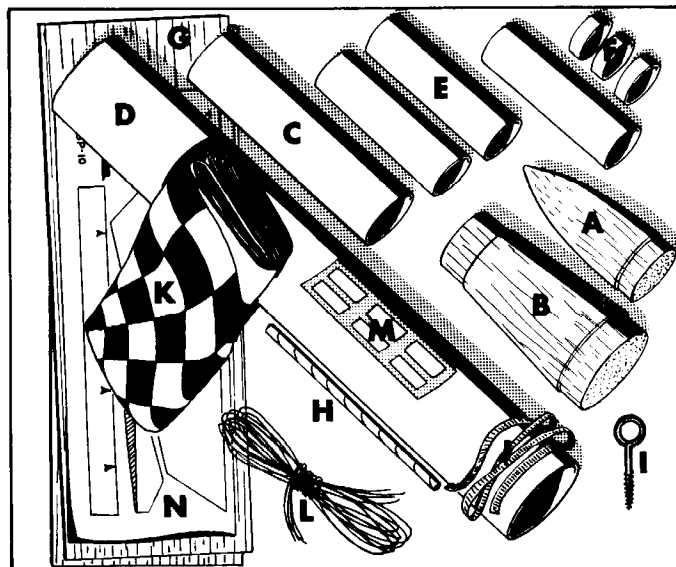

Astron Cobra

Your Astron Cobra rocket kit consists of the following parts as illustrated in the drawing at right:

- (A) 1 Nose Cone--Part #BNC-50K
- (B) 1 Adapter--Part #TA-5060
- (C) 1 Payload Tube--Part #BT-50S
- (D) 1 Body Tube--Part #BT-60D
- (E) 3 Engine Holder Tubes--Part #BT-20J
- (F) 3 Engine Blocks--Part #EB-20A
- (G) 2 Sheets Fin Stock--Part #BFS-40
- (H) 1 Launching Lug--Part #LL-1C
- (I) 1 Screw Eye--Part #SE-1
- (J) 1 Shock Cord--Part #SC-2
- (K) 1 Parachute--Part #PK-18A
- (L) 144" Shroud Line Cord--Part #SLT-14
- (M) 6 Tape Strips--Part #TD-2F
- (N) 1 Pattern Sheet--Part #SP-10



In addition to the materials included with your kit you will need the following tools and supplies:

1. Modeling knife or single edge razor blade.
2. Scissors.
3. Extra strong white gluc.
4. A sharp, pointed punch.
5. Ball point pen or pencil.
6. Fine and extra fine grit sandpaper.
7. Paint or dope.
8. Kleenex or similar paper.

Check to be sure your kit is complete. Then read the entire instructions before beginning to assemble your rocket.

Construction

(1) Glue the engine blocks into the engine holder tubes. This is done by applying glue to 1/4" of the inside of the tube at one end and slipping the engine block into place so the rear end of the block is even with the rear end of the tube. All three blocks must be glued in the tubes securely. (See fig. 1.)

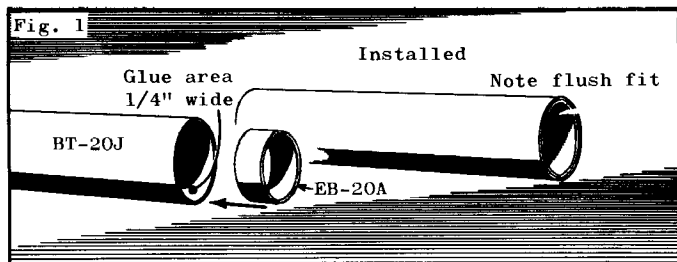

(2) Glue the three engine holder tubes together. First run a strip of glue down one side of one of the tubes. Place another tube against it so the sides and ends of the tubes are matched with the engine blocks at the same

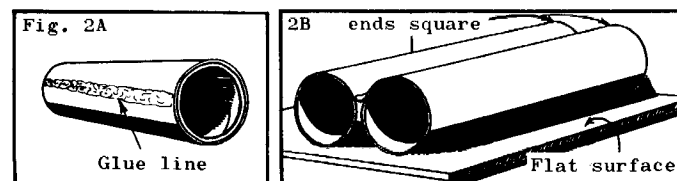

end and the tubes run perfectly parallel to each other. Glue the third tube to the first two in the same way. The completed assembly is shown in fig. 2C.

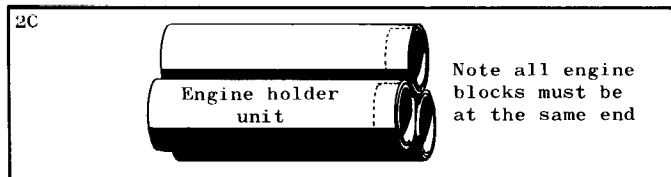

(3) Apply glue liberally to the inside of one end of the main body tube. The glue may be in three strips spaced equally around the inside of the tube and pointing forward. Insert the engine holder assembly, engine block end first, into the end of the body. Insert it so the entire assembly is inside the body with the end of the engine holder tubes even with the end of the body. Turn the engine holder assembly until each of the small tubes makes a good contact with the glue.

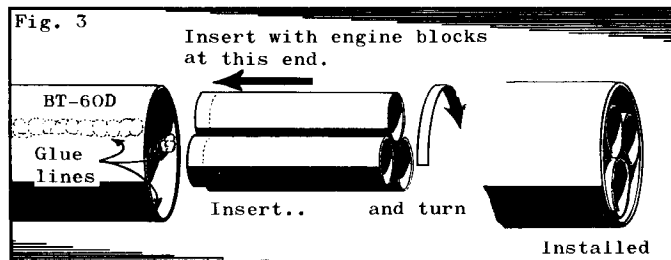

(4) Moisten small wads of kleenex or similar paper with glue and pack them into the gap areas between the engine holder tubes and the body tube and into the hole between the engine holder tubes in the middle. This packing should fill the rear 1/2 inch of the gap area. Work the wadding into place to completely fill and seal all holes and gaps. When this step is completed the only route for air to pass through the body tube should be through the engine holder tubes. This is to prevent leakage of

the ejection charge gases and eliminate recovery failures caused by the gases exhausting rearward instead of pushing the 'chute and payload section out the forward end of the rocket. If there are any leaks, the recovery system will not work and the rocket will be damaged on landing.

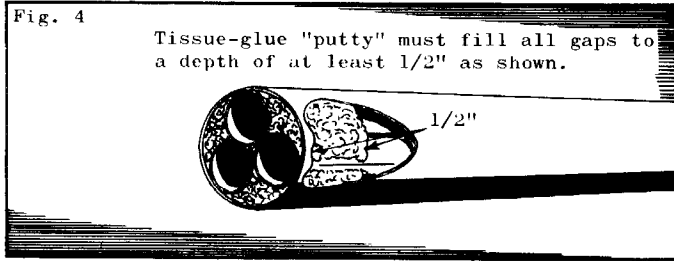

Make Fins Next

(5) Cut out the fin pattern. Lay it on a sheet of balsa and align it so that the grain of the wood is exactly in line with the grain shown on the pattern. Trace around the pattern, then move it to the other end of the sheet and trace again. If the pattern is placed as shown in fig. 5 it will be possible to cut two fins from each sheet of balsa. Cut out the fins using a sharp modeling knife or single edge razor blade.

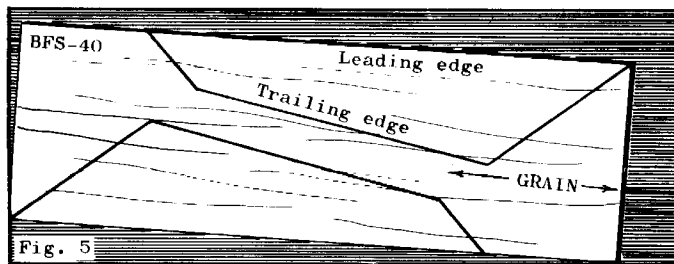

(6) Using fine grit sandpaper round the leading edge and taper the trailing edge of each fin to match the airfoil shown on the pattern sheet and in fig. 6. Sand the root edge (the edge that attaches to the body) of each fin until it is flat and square with the sides of the fin. Smooth off the surfaces of the fin with extra fine sandpaper.

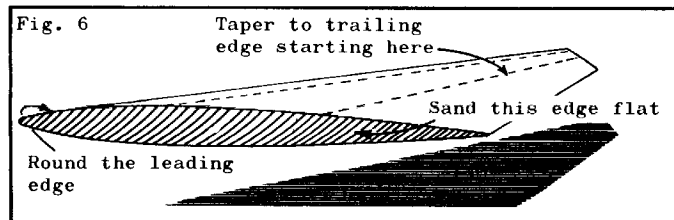

(7) Cut out the fin spacing guide on the dotted lines. Wrap it around the rear of the body tube and mark at the arrows as shown in fig. 7. When this has been done there should be four equally spaced marks on the body tube.

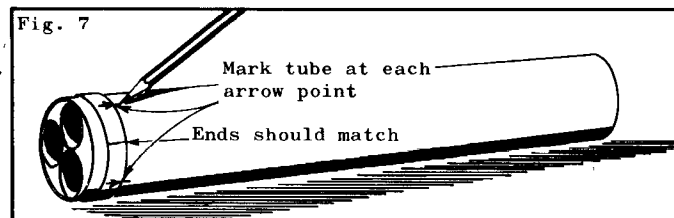

(8) Apply glue to the root edge of one fin and press this edge against the body directly over one of the marks from step 7. Align the fin by sighting along the body and shifting the fin until it is perfectly straight and projects straight out from the body. Hold the fin in position until the glue starts to set, then repeat with the other fins. Do not set the rocket on its fins while the glue is wet.

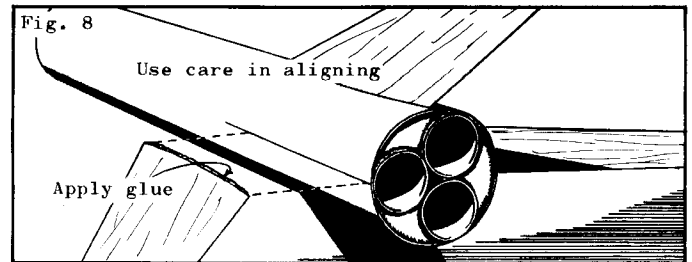

(9) Apply a line of glue to one side of the launching lug and press it against the body as shown in fig. 9A.

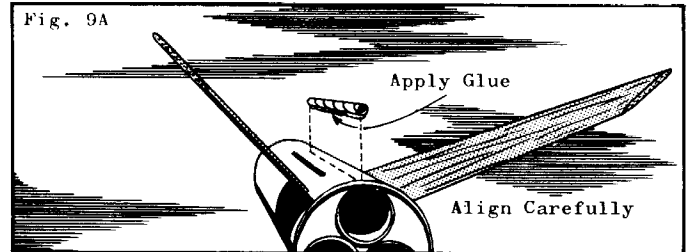

Sight along the body and align the lug so it is perfectly straight. Next apply a glue fillet to the launching lug and to each fin-body joint as shown in fig. 9B. Wipe off all excess glue, leaving only enough to form a smooth fillet.

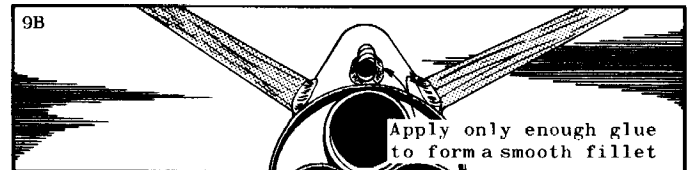

RECOVERY SYSTEMS You may select

(10) There are two methods for attaching the recovery system on your Astron Cobra. The one, described in section (a) below, lowers the main body of the rocket nose first, reducing the possibility of fin damage on landing. The other, described in (b), lowers the main body tail first, but gives a somewhat cleaner and less cluttered outside appearance to the rocket. Follow either (a) or (b), but follow only one of the steps.

METHOD "A"

(a) Punch a small hole in one fin 1-1/2" ahead of the rear of the body. The hole should be as close to the body wall as possible. Cut a 14" length of shroud line cord and tie a large knot in one end of the cord. Insert the other end of the cord through the hole and pull it through until the knot is against the fin. Apply glue to both sides of the hole to securely anchor the cord in place. Tie the other end of the cord to one end of the shock cord. (This attachment method is shown in fig. 10A.)

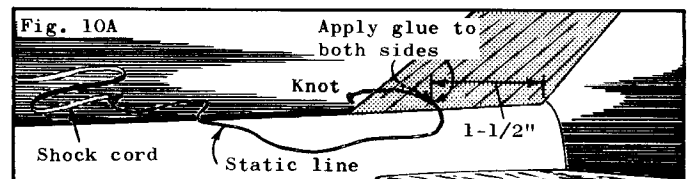

METHOD "B"

(b) Cut two 1/2" long slits in the forward end of the body, the one directly behind the other, 3/4" and 1" from the front of the body. Cave in the portion between the two slits and slide one end of the shock cord through

the opening. Tie a knot on the inside end of the cord. Pull the knot against the slits and apply glue under and over the shock cord and along the cut edges of the body tube. Reach inside and push the caved-in portion outward as near to its original position as possible.

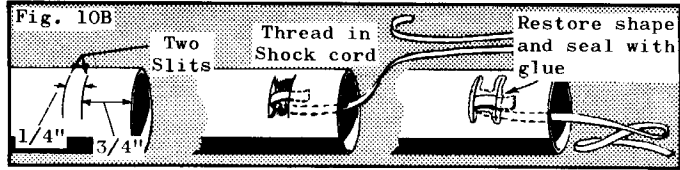

PAYLOAD UNIT & 'CHUTE ASSEMBLY

(11) Apply glue to the inside of the payload section tube at one end and slide the tube onto the small end of the adapter. Twist the screw eye into the center of the other end of the adapter, remove the eye, squirt glue into the hole and replace the screw eye.

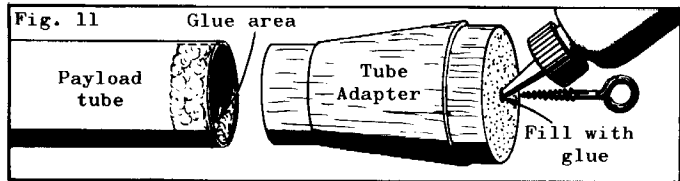

(12) Cut out the parachute on its edge lines. Cut six 18" lengths of shroud line cord and attach one shroud line to each point of the 'chute with a tape strip as shown in fig. 12A. Tie the free ends of the shroud lines

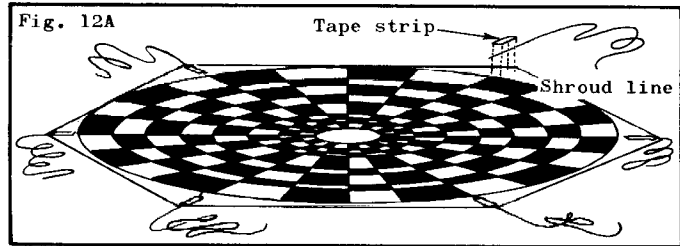

together. Connect the shock cord, parachute and screw eye as shown in fig. 12B. Push the parachute into the body tube, packing the shroud lines and shock cord over it. Push the payload section into place on the forward end of the model. Place the nose cone on the forward end of the payload section.

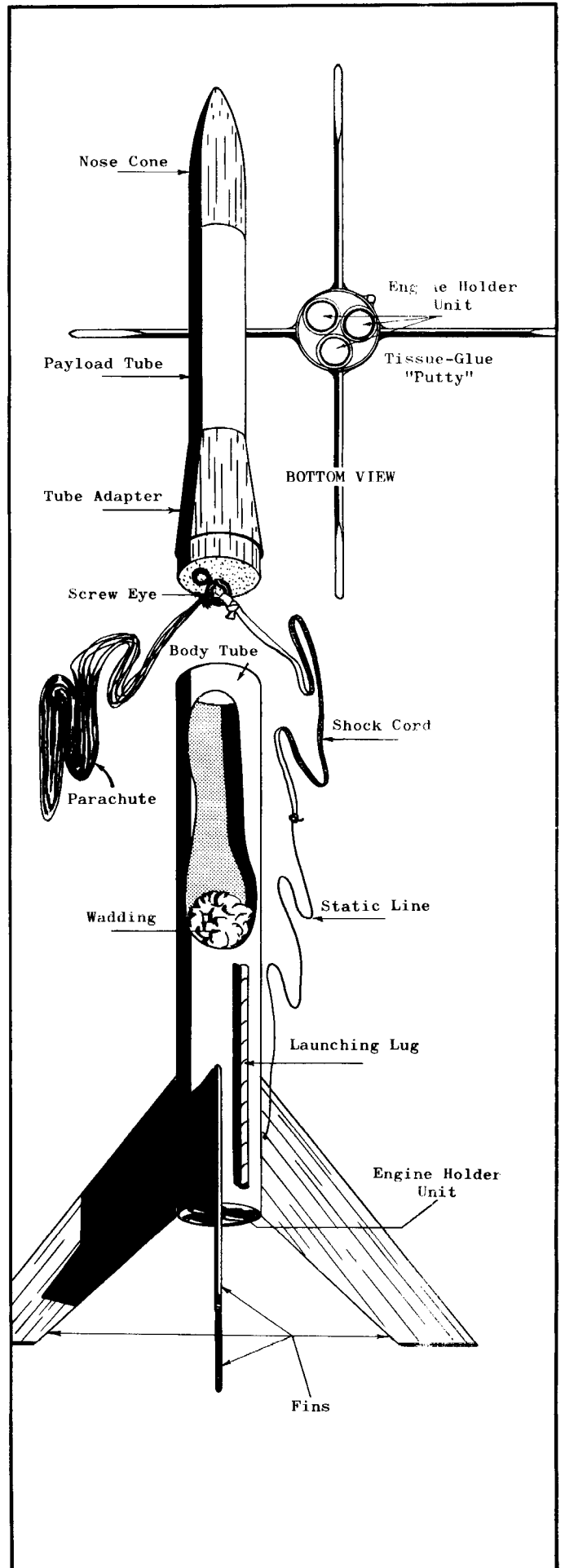
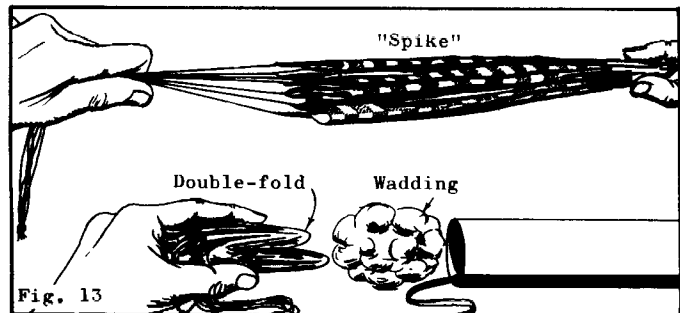
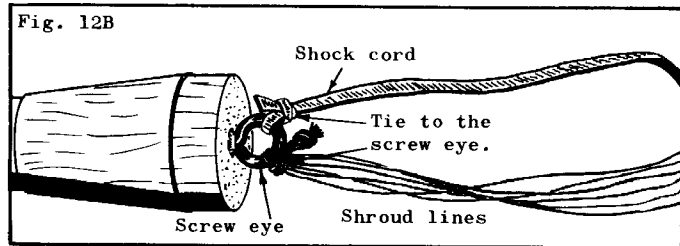

Finishing

(13) Before finishing let all the glue on the outside of the rocket dry so it is hard and clear. Either butyrate dope or spray enamel may be used for finishing. For ease of painting spray enamel is recommended. First apply a coat of sanding sealer to all wood surfaces. Let it dry completely and then sand lightly. The mylar backed sanding material is best for this as it will fold and allow close sanding in tight places. Apply a second coat, sand and apply still another coat until all the pores in the balsa are filled and the surfaces look and feel smooth. When the sanding sealer is completely dry brush on the butyrate dope finishing coats or spray on the enamel finish. If you choose enamel give the entire model one or more coats of gloss white to obtain a neutral base for following colors.

For an extra slick finish apply a coat of paste wax, let dry and buff to a high gloss. Use wax only when the paint is completely dry. Do not use wax over fluorescent paint or decals. NOTE: Spray enamel may be applied over completely dry dope, but never attempt to brush dope over enamel as it will make the enamel craze and blister.

Flying the Astron Cobra

- 1) Read Estes Industries Technical Report TR-6 completely before preparing your Astron Cobra for its first flight. The procedures outlined in the report will be used in flying the Cobra.
- 2) Pack flameproof recovery wadding into the body tube from the top. The wadding should rest against the engine holder tubes, extend forward in the tube for about 2" and seal tightly against the sides of the tube. Hold the parachute between two fingers at its center and pass the other hand down it to form it into a "spike" shape. Fold this spike in three sections as shown in fig. 13. Push the folded parachute down into the tube on top of the wadding and pack the shroud lines and shock cord in on top of the parachute. Slide the adapter into place.
- 3) Before inserting the rocket engines tamp flameproof wadding into the ejection end of each so it will be impossible for the ejection charge of one engine to reach the ejection charge of another engine which did not ignite at launching. Then wrap the engines with tape to make a tight friction fit in the engine holder tubes. This fit must be tight so the engines will not blow out at ejection. Install igniters as directed in TR-6.
- 4) Launch the Astron Cobra with an approved, electrically operated model rocket launching system. Consult our catalog or the store where you purchased your rocket for further details. The launcher base must be anchored to the ground or weighted down. If a two-piece rod is used the sections should be soldered together. They may be unsoldered later if the rod is used only with lighter rockets.
- 5) Use caution when flying model rockets. Do not launch in high winds, near low flying aircraft or around persons not participating in or watching the launching. Always follow an approved model rocket safety code. Inspect the model carefully after each flight to make sure it has not been damaged and is in satisfactory condition for the next flight. Extra care is required since a cluster rocket is not always as reliable as a single engine model.

6) The engine types recommended for use in the Astron Cobra are the A-8-3, B-8-4 and B-3-5. The type to use will depend on desired altitude, payload weight and the ignition system. A-8-3 engines are recommended for first flights using the direct electrical system. Maximum recommended payload weight for the Cobra is 1 oz. with type A engines and 3 oz. with type B engines.

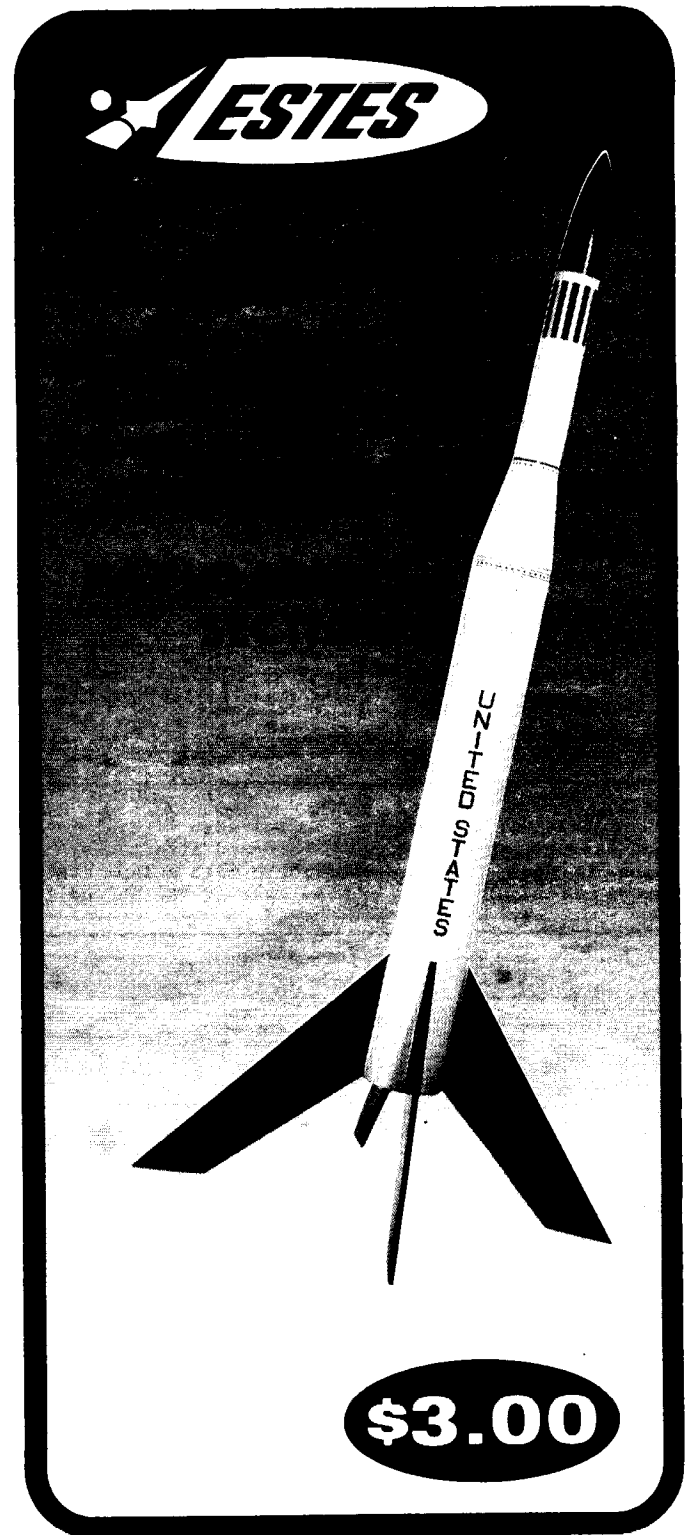

COBRA

KIT NO. K-10 \$3.00

SPECIFICATIONS	RECOMMENDED ENGINES
Body Dia: 1.6 in.	A8-3, B6-4, C6-5
Length: 22.25 in.	All 3 must be same
Weight: 2.25 oz.	(Use B6-4 for first flight)

PARACHUTE RECOVERY

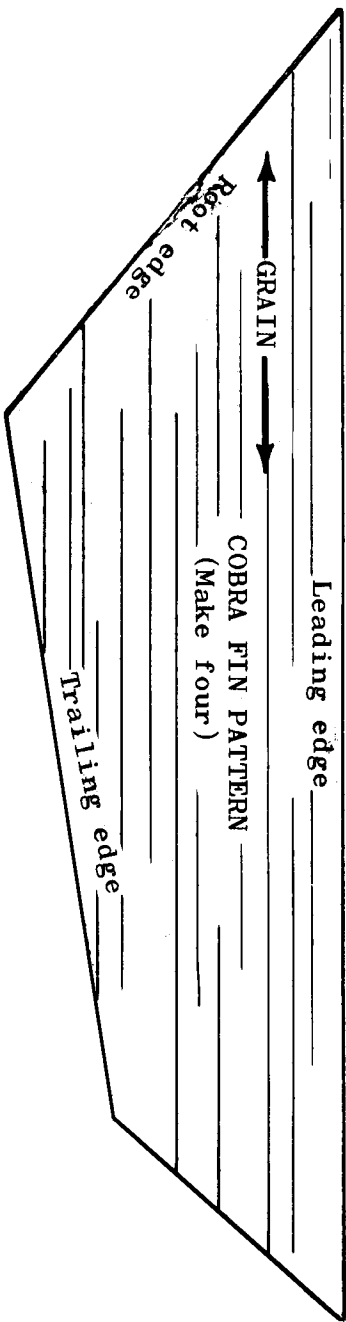

Leading edge

GRAIN

COBRA FIN PATTERN
(Make four)

Trailing edge

Root edge

Astron Cobra

Kit Design by Estes Industries

Drawn by Peter Alway

Parts:

- A) Nose Cone BNC-50K
- B) Adapter TA-5060
- C) Payload Tube 4" BT-50
- D) Body Tube 11" BT-60
- E) Engine Holder Tubes (3) 2.75" BT-20
- F) Engine Blocks (3) EB-20A
- G) Fins (4) from 1/8" Balsa
- H) Launch Lug (5" long in original kit)
- I) Screw Eye
- J) Shock cord 1/4" x 18"
- K) 18" Parachute
- L) 14" Static Line Heavy Duty Thread (optional)

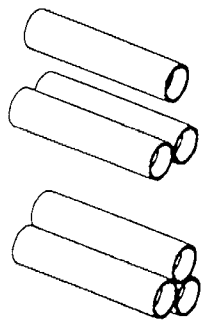
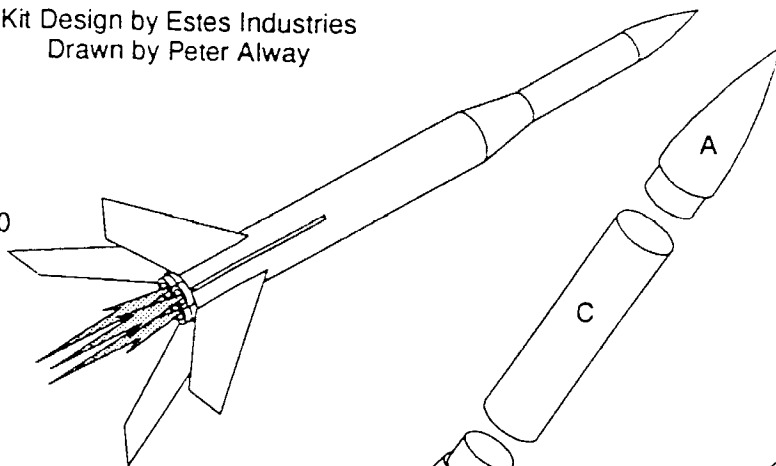

Glue a pair of engine tubes together on a flat surface, allow to dry, and glue third in place. Don't forget the engine blocks.

One end of static line is attached to a fin, the other end is tied to shock cord, so body section will hang by a fin root on recovery.

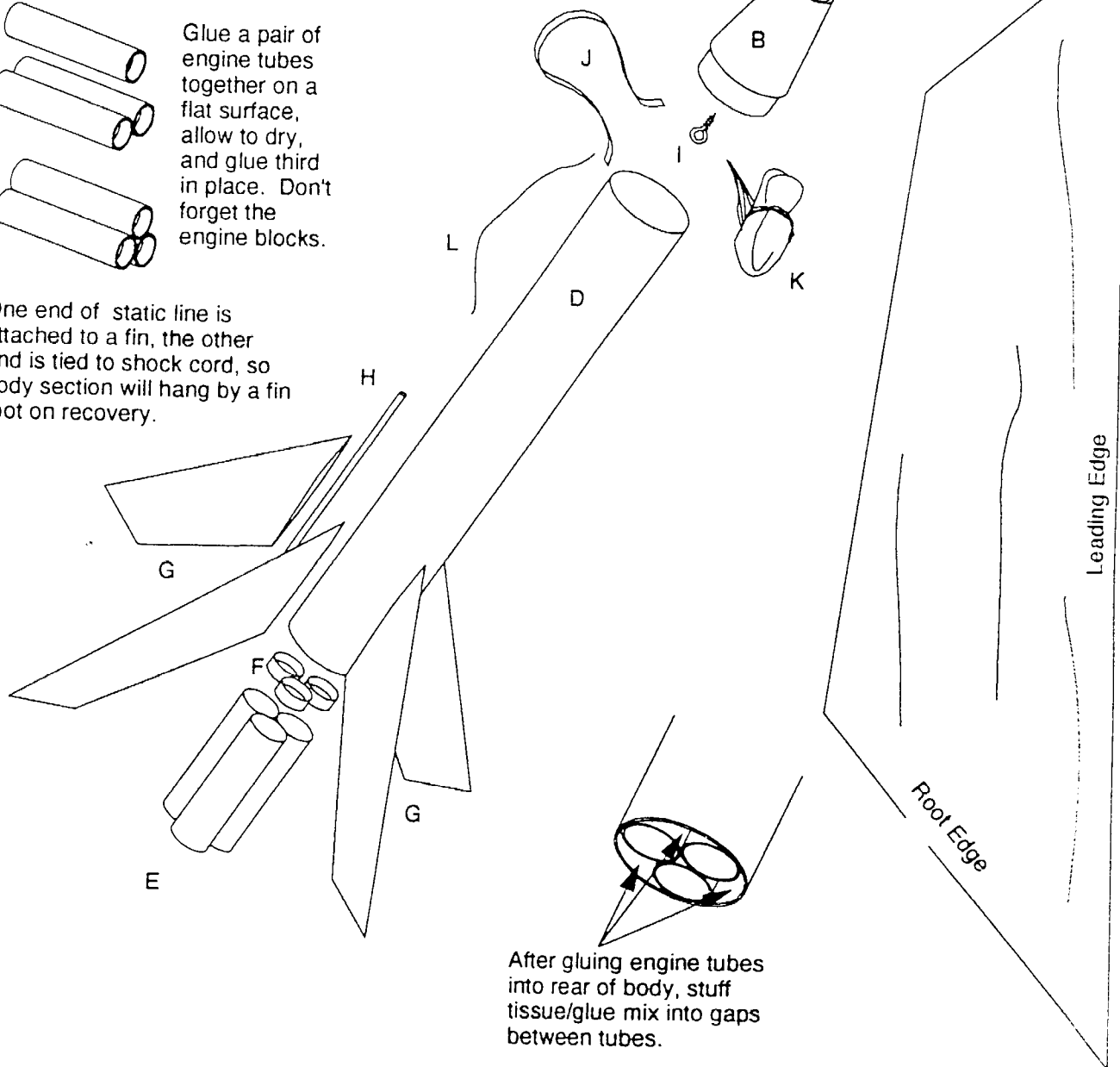

After gluing engine tubes into rear of body, stuff tissue/glue mix into gaps between tubes.